

WORLD'S MOST
ACCURATE & FASTEST RIBBON SPLICER

VIEW 12R +

—
MOTORIZED CLAMP
ALIGNMENT SYSTEM

—
THE HIGHEST
MAGNIFICATION
AND RESOLUTION

—
DOUBLE TAPPING
(ZOOM IN & OUT)

—
THE FASTEST
WORKING TIME

—
5" COLOR LCD
TOUCH SCREEN

—
UNTRA-HIGH
CAPACITY
BATTERY

—
UNIVERSAL SINGLE
FIBER HOLDER

—
NANO-COATED
ELECTRODE



CHARACTERISTICS



Fast Heating up to 20s
(max 14s during
consecutive heating)

Highly Durable Electrode
by Nano Coating

3 Bright LEDs for dark
environment

5" Touch Screen with
Smart GUI

The Highest 250X
magnification

Double Tap to Zoom
in & out

Protected by tempered
glass film

Motorized Clamp -
Improved Accuracy



Longest Battery
Capacity with typical
220 cycles

Replaceable Fiber
Holder from Single
to 12 Fibers

DESCRIPTION

View 12R+, a ribbon splicer with the fully motorized clamp alignment system, is the most powerful and state-of-the-art ribbon splicer in the market. Its advanced automatic clamp alignment system offers more accurate and dependable ribbon fiber splicing up to 12 fibers with the double-tapping (Zoom in & out) to the world's highest magnification of 250x. View 12R provides maximum work efficiency through the fast splicing & heating time, ultra-high battery capacity of 220 splice/heat cycles, and universal holder both for 250µm & 900µm single fiber. View 12R ensures the most reliable work experiences to our valuable customers.

MOTORIZED CLAMP ALIGNMENT SYSTEM

View 12R's advanced clamp activates itself in accordance with the position of fiber so that each cores of individual fiber are correctly placed on its assigned v-groove. There is no doubt that this process enables more accurate and reliable splicing process.



SPECIFICATIONS

VIEW 12R+

Model	View 12R+
Dimension	160H x 133W x 155D mm (excluding rubber bumper) / 167H x 143W x 163D mm (including rubber bumper)
Weight	1.98 KG (without battery) / 2.64 KG (with battery)
Number of Fiber	1, 2, 4, 6, 8, 10, 12
Applicable Fibers	SM(ITU-T G.652&G.657) / MM(ITU-T G.651) / DS(ITU-T G.653) / NZDS(ITU-T G.655)
Compatible Fiber / Cable	Ribbon: 0.25~0.4 mm / Single: 250 µm & 900 µm
Cleaved Length	10 ~ 13 mm
Cladding Diameter	125 µm
Splicing Mode	Max 100 modes
Heating Mode	Max 32 modes
Typical Splice Loss	SM: 0.05dB / MM: 0.02dB / DS: 0.08dB / NZDS: 0.08dB (ITU-T standard)
Return Loss	→→ 60 dB
Lighting	3 White LEDs
Splicing Time	Ribbon fiber: 15 sec / Single fiber: 9 sec
Estimated Splice Loss	Available
Heating Sleeve Length	60mm, 50mm, 40mm, micro
Heating Time	Typical 20 sec
Results Storage	The last 2000 results
Tention Test	1.96~2.25N
Operating Condition	Operating Altitude: 0~3,660m above sea level / 0~95% relative humidity / -10~50°C / Max Wind 15m/s
Storage Condition	0~95% relative humidity / -40~80°C
Display	90° bi-directional view, 5.0" Color High Resolution Display
Fiber View & Magnification	X, Y, XY, X/Y : 250X Magnification
Power Supply	AC Input 100-240V, DC Input 9-14V
No. of Splice & Heating with Battery	8700mAh Battery Capacity / Typical 220 times (Splice + Heat)
Operating Methods	Button / Touch Screen
Automatic Calibration	Automatic arc calibration by air pressure and temperature
Electrode Life	1500 arcs, can be extended by using an electrode grinder
Terminal	DIN / Micro HDMI

WEIGHT AND DIMENSIONS

Height	6.29 inches (160mm)
Width	5.23 inches (133mm)
Depth	6.10 inches (155mm)
Weight	4.36 pounds (1.98kg without battery)

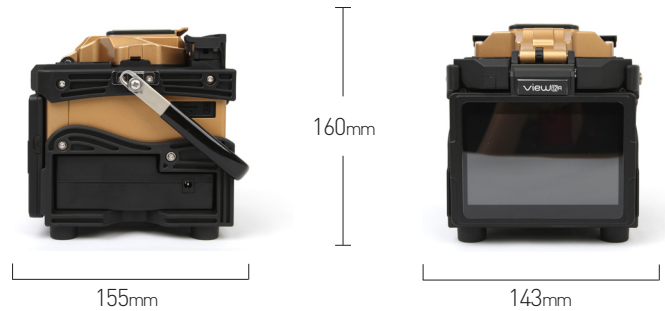

PACKAGE

Fusion Splicer	View 12R
High Precision Cleaver	V7
Thermal Stripper	TS-8
Fiber Holder	12 Ribbon: FH-12L / FH-12R 8 Ribbon: FH-8L / FH-8R 4 Ribbon: FH-4L / FH-4R 250 & 900µm Single: FH-UL / FH-UR (Universal) SOC Holder: FH-SOC-R
SOC Heater Cover	HTS-SOC
AC Adapter	JS-180300
Cooling Tray	CG-22
Electrode	E-50
Electrode Grinder	EG-18
Manual CD	CD
Battery Pack	LBT-20
Power Cable	ACC-25
Micro HDMI to USB Cable	HDMI-15
DIN Cable	DIN-18
Cigarette Lighter Cable	CJ-11
Thermal Stripper Charger	AR-8
Protection Sleeves	PS-12R-40
V-Groove Cleaning Brush	CB-01
Carrying Case	NBX-35

OPTIONAL PACKAGE

Fiber Holder	10 Ribbon FH-10L / FH-10R 6 Ribbon FH-6L / FH-6R 2 Ribbon FH-2L / FH-2R 250µm Single FH-250L / FH-250R 900µm Single FH-900L / FH-900R
---------------------	---



You dream,
we DESIGN

Copyright© 2015 INNO Instrument Inc. All right reserved.
E-22F, 30, Songdomirae-ro, Yeonsu-gu, Incheon 406-840, Republic of Korea
tel 82-32-837-5600 fax 82-32-837-5601

Please visit us on Facebook
www.facebook.com/innoinstrument